



# Quality Packaging Systems

## Full Range of Unitized Shrink Systems

**U2228D • U1824 • U1319**

- Safe & Easy Seal Wire System
- Excellent warranty coverage
- More standard features



U2228D



U1824

Pack-All Unitized Systems provide a complete shrink packaging capability in a full range of sizes.

The right system for a wide spectrum of products and packaging requirements.

Call and let us know how we can help improve your packaging capabilities.



U1319

Pack-All, Inc., 3003 Hirsch Street  
Melrose Park, IL 60160

[www.pack-all.com](http://www.pack-all.com) 888-806-9800



Made in USA





**Model U2228D** – the ultimate Unitized System providing the largest seal area and shrink tunnel available in a unitized system and featuring Single Level Product Transfer.

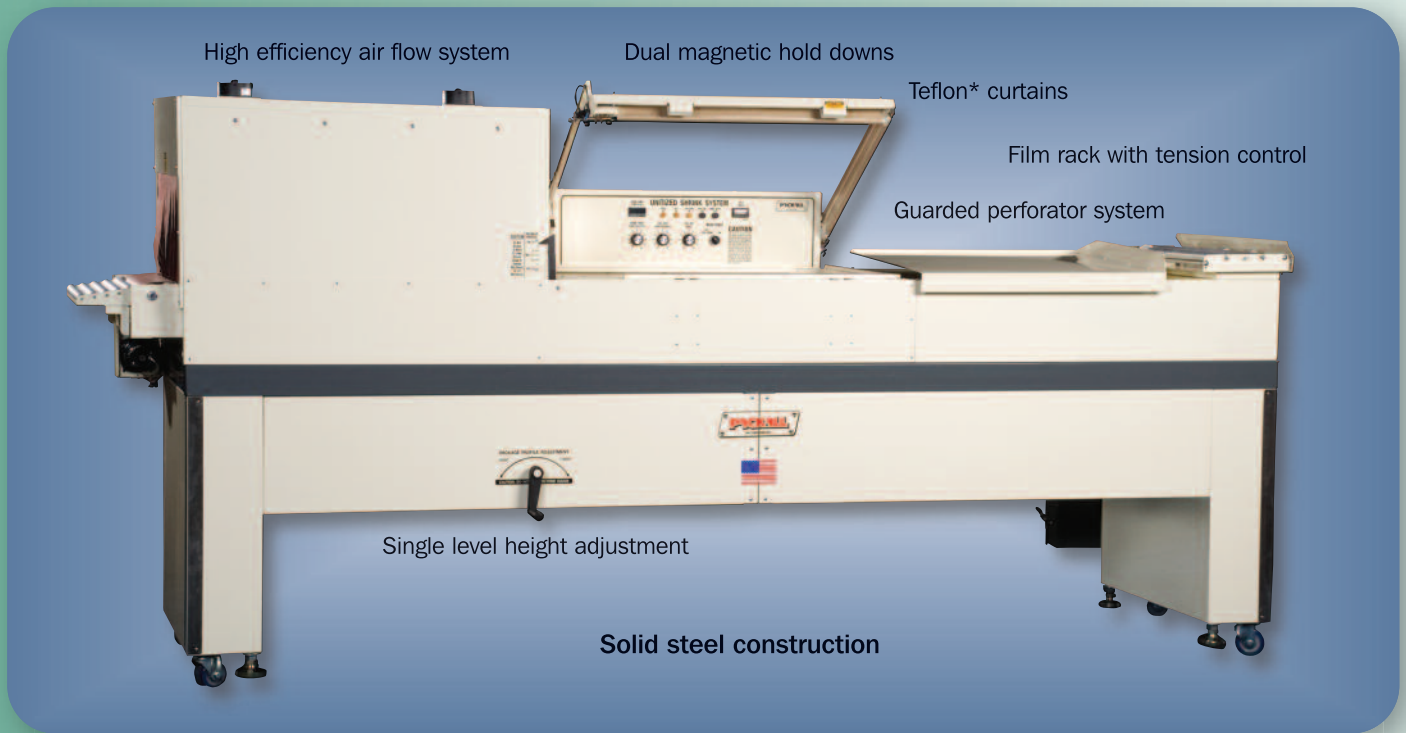

**Single-level product transfer**



Height gauge



For low profile product



For high profile product

Seal area and tunnel conveyors are adjustable and operate at the same speed and height at all times

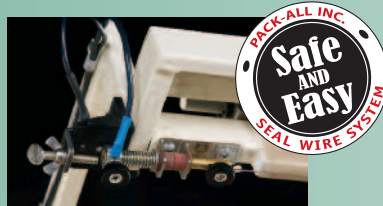

Safe and Easy wire changes with NO TOOLS!



**Precision control panel**

- Variable speed tunnel conveyor control
- Digital temperature controller
- Adjustable dwell timer
- Automatic cool down
- Cycle counter

**Options available:**

- Spare parts kit
- Rear film unwind and inverting plow for in-line product feeding
- Accumulation tables

**Standard features include:**

- Single-level product transfer
- Safe & Easy seal wire system - NO TOOLS REQUIRED
- Soft touch seal head reduces operator fatigue
- Guarded film rack/perforator system
- Magnetic hold-down
- Teflon curtains shielding seal wires
- Variable speed tunnel conveyor
- Precision digital temperature controller
- Automatic tunnel cool-down
- Automatic take-away conveyor
- **30-month warranty**

**U2228D specifications:**

Seal area: 22"W x 28"L  
 Shrink tunnel chamber: 35"L x 23"W x 12"H  
 Overall dimensions: 122"L x 38"W x 56"H  
 Weight: 825 lbs.  
 Power required: 208 or 220V/1Ph/30A with single power cord connection



**Model U1824D** – the most cost-effective system for a broad spectrum of products and production requirements featuring a larger seal area & shrink tunnel with multiple heaters and blower motors.

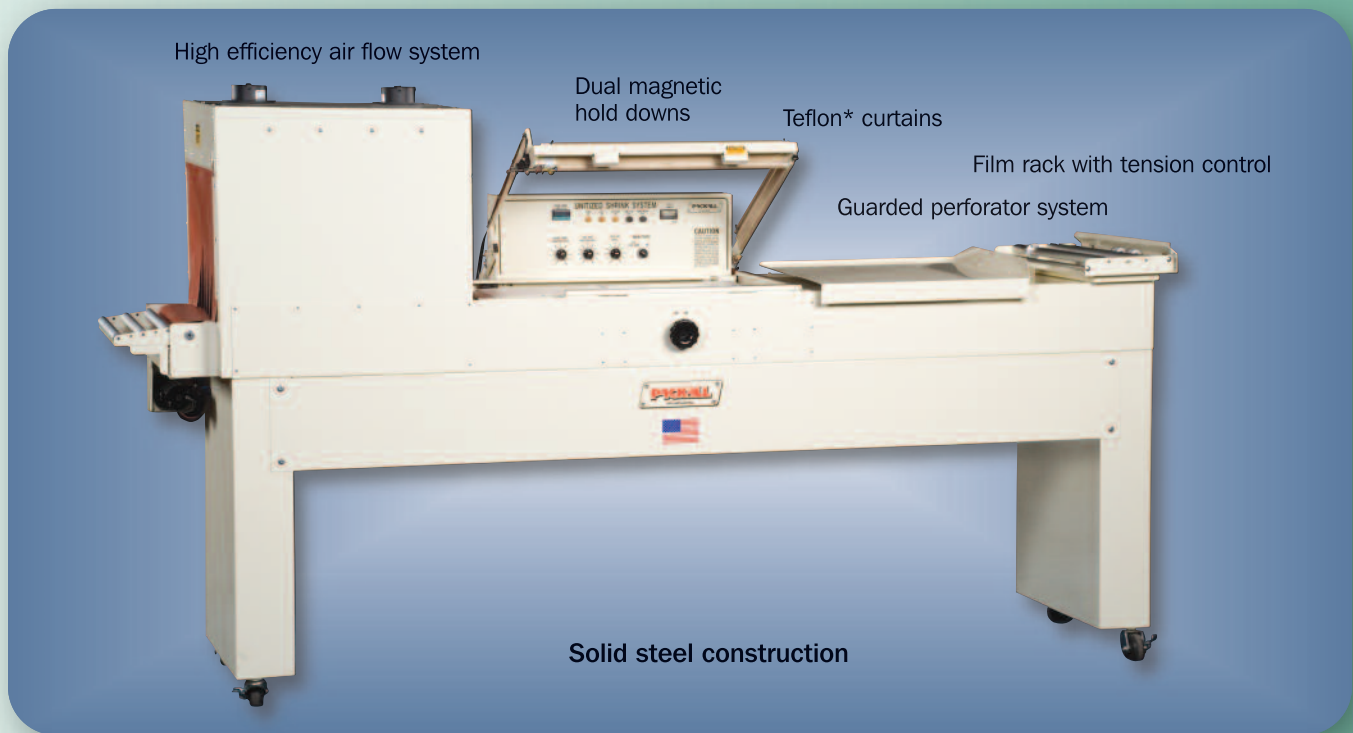

High efficiency air flow system

Dual magnetic hold downs

Teflon\* curtains

Film rack with tension control

Guarded perforator system

Solid steel construction

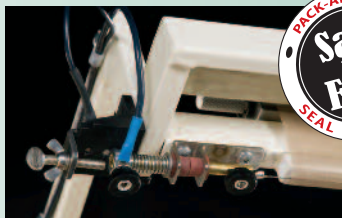

Safe and Easy wire changes with NO TOOLS!



**Precision control panel**

- Variable speed tunnel conveyor control
- Digital temperature controller
- Adjustable dwell timer
- Automatic cool down
- Cycle counter

**Standard features include:**

- Safe & Easy seal wire system - NO TOOLS REQUIRED
- Soft touch seal head reduces operator fatigue
- Guarded film rack/perforator system
- Magnetic hold-down
- Teflon curtains shielding seal wires
- Variable speed tunnel conveyor
- Precision digital temperature controller
- Automatic tunnel cool-down
- Automatic take-away conveyor
- **2-year warranty**

**U1824D specifications:**

Seal area: 18"W x 24"L  
 Shrink tunnel chamber: 24"L x 20"W x 12"H  
 Overall dimensions: 103"L x 32"W x 56"H  
 Weight: 450 lbs.  
 Power required: 208 or 220V/1Ph/25A with single power cord connection

**Options available:**

- Spare parts kit
- L-R product flow
- Stainless steel construction
- Hot hole punch
- Heavy products capability
- Accumulation tables



**Model U1319** – compact, easy-to-use shrink packaging system for use in a wide range of product applications and production environments.

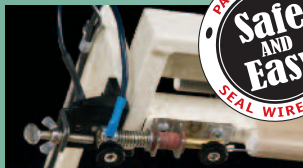
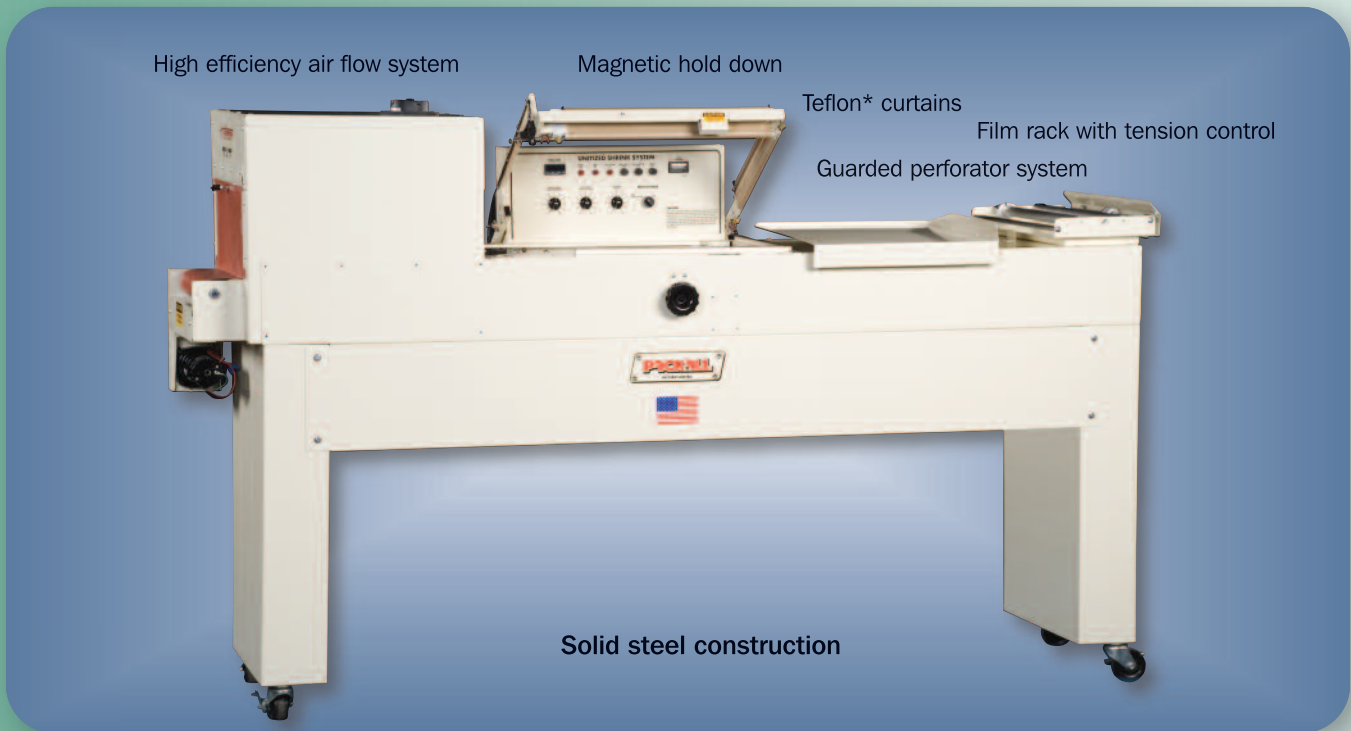

Safe and Easy wire changes with NO TOOLS!



**Precision control panel**

- Variable speed tunnel conveyor control
- Digital temperature controller
- Adjustable dwell timer
- Automatic cool down
- Cycle counter

\*Teflon is a registered trademark of the DuPont Corp.

**Standard features include:**

- TurboFlow™\*\* - adjustable air flow for more consistent film shrinkage
- Safe & Easy seal wire system - NO TOOLS REQUIRED
- Guarded film rack/perforator system
- Magnetic hold-down
- Teflon curtains shielding seal wires
- Variable speed tunnel conveyor
- Precision digital temperature controller
- Automatic tunnel cool-down
- **2-year warranty**



**TurboFlow™\*\***

\*\*Trademark of Pack-All, Inc.

**Options available:**

- Spare parts kit
- Voltage upgrade to 208 or 220V
- Automatic take-away conveyor
- Heated hole punch
- L-R product flow
- Heavy products capability
- Stainless steel construction
- Accumulation tables

**U1319 specifications:**

- Seal area: 13"W x 19"L
- Shrink tunnel chamber: 20"L x 14"W x 8"H
- Overall dimensions: 84"L x 27"W x 54"H
- Weight: 300 lbs.
- Power required: 120V, 20A
- U1319D: with automatic product take-away
- U1319C: without automatic product take-away

Distributed by

